

Stand vertically in or behind the fork to check clearance. View from front of bike looking back through forks. It is important to check that the motor does not interfere with the forks when installed.



## Disc Brake Motor Template

Please print this template onto A4 selecting "Actual Size" and check the 100mm dimension with a ruler before removing front wheel and positioning template to confirm fork clearance.

Bicycle Fork

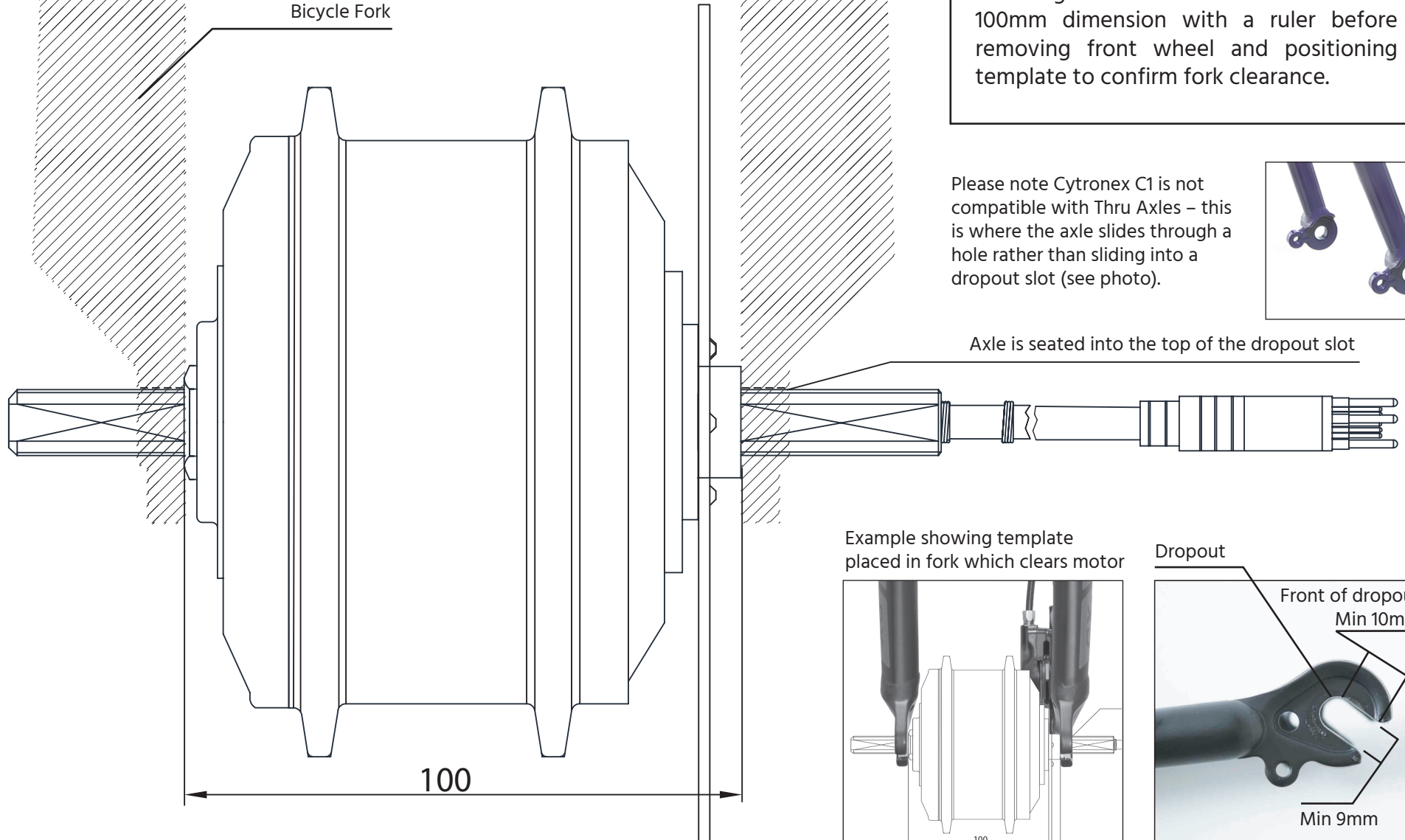

Please note Cytronex C1 is not compatible with Thru Axles – this is where the axle slides through a hole rather than sliding into a dropout slot (see photo).



Axle is seated into the top of the dropout slot

Example showing template placed in fork which clears motor

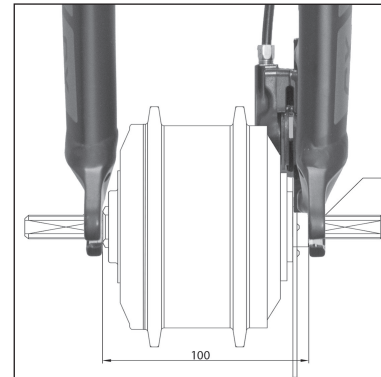

Dropout

