

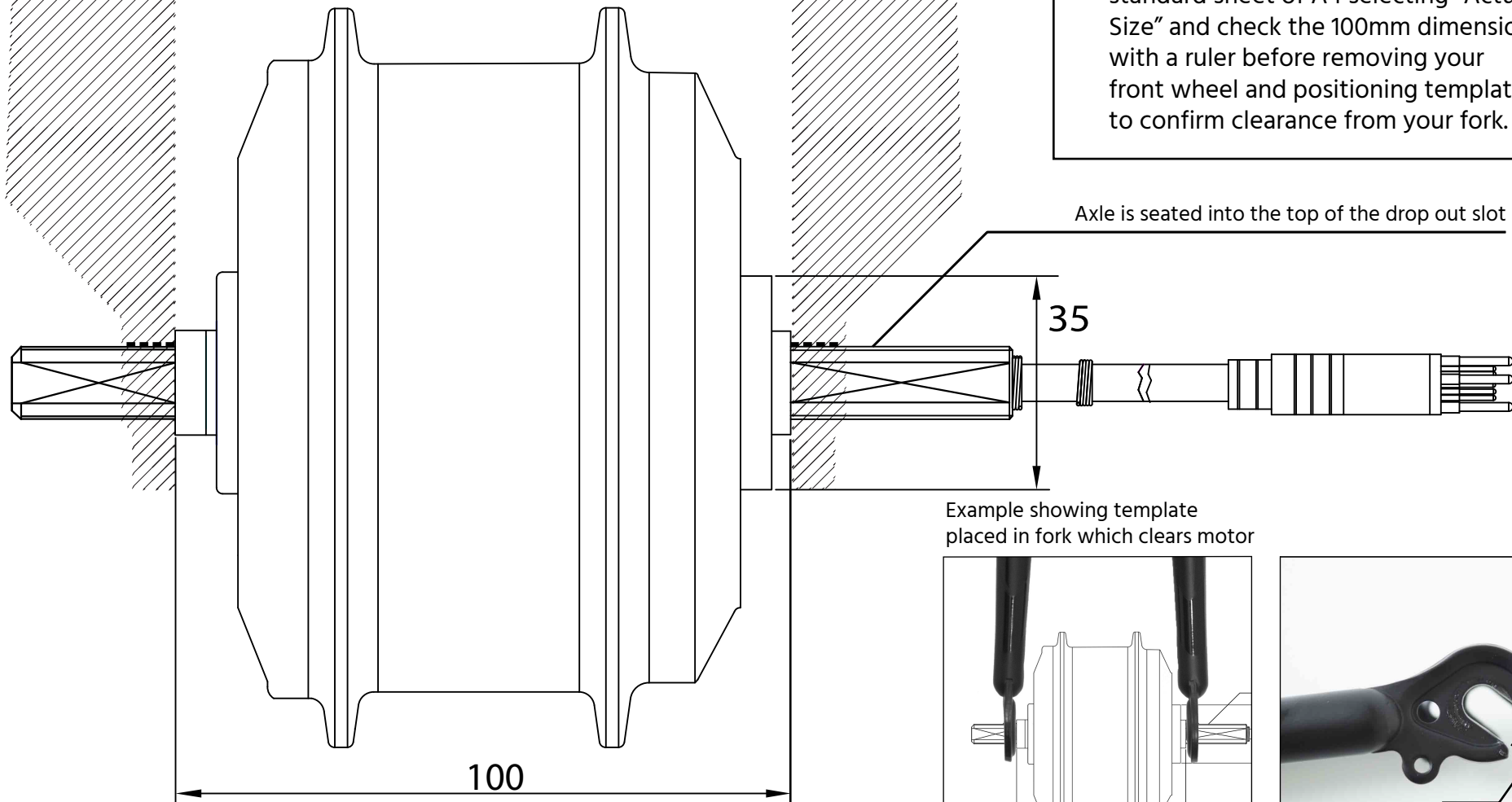

Rim Brake Motor Template incl. V-Brake and Caliper Brake

Please print this template onto a standard sheet of A4 selecting "Actual Size" and check the 100mm dimension with a ruler before removing your front wheel and positioning template to confirm clearance from your fork.

Stand vertically in or behind the fork to check clearance. View from front of bike looking back through forks. It is important to check that the motor does not interfere with the forks when installed.



Example showing template placed in fork which clears motor

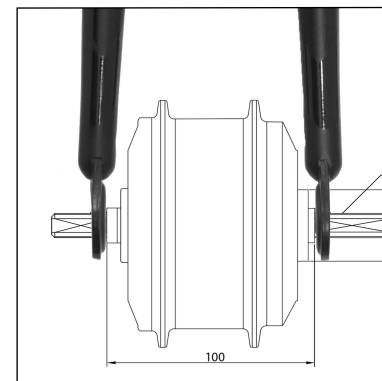

Min 9mm